

## THE IMPACT OF EU PALM OIL RESOLUTION ON THE PERFORMANCE OF ASEAN MACROECONOMIC AND TRADE AND CHANGE IN WORLD SOCIETY WELFARE

Haryadi  
Siti Hodijah

### ABSTRACT

*The main objectives of this research are (1) to analyze the flow map of world palm oil trade, (2) to analyze the impact of palm oil resolution by the European Parliament on ASEAN macroeconomic and sectoral performance, (3) to analyze the impact of palm oil resolution on the society welfare of the European Union (EU). This study uses a multi-country general equilibrium model known as the General Trade Analysis Project (GTAP) model. The simulation results show that (1) the EU is not the main export destination of ASEAN countries (Indonesia, Malaysia and Thailand). Although the EU's market share is quite large, none of the ASEAN countries makes the EU a major export destination. (2) implementation of the palm oil resolution policy by the EU, although it has a negative impact on the macroeconomic performance of the world's largest palm oil exporting countries, but the impact is relatively small both on macro and sectoral economic performance, (3) the implementation of the palm oil resolution policy not only reduces the welfare of the community in the palm oil producing countries, but also decreases the welfare of The EU itself. Based on these findings, we came to the conclusion that the resolution of palm oil did not have a significant effect on ASEAN economic performance and was even worse in relation to the welfare of the people in the EU.*

Keywords: Palm Oil Resolution, ASEAN, GTAP Model, Macro and Sectoral Economic impact, Welfare and employment

### I. INTRODUCTION

#### 1.1. Background

The existence of the ASEAN economic community as one of the world's economic powers, is estimated to have caused anxiety for several trade groups including the European Economic Community (EU). In addition to the already high level of competition and the difficulty of these countries to enter the ASEAN market, there are also fears of the growing urgency of these countries to face the rapid flow of exports from ASEAN. This condition gives rise to protection of their products (Fajgelbaum et.al. 2018, Khairunnisa and Tanti, 2017).

One of the commodities that can threaten the production of EU's palm products and their derivatives. Based on data, more than 92.1 percent of world palm oil production is produced in ASEAN. The data in Table 1 shows that the 3 (three) major producers of world palm oil are Indonesia, Malaysia and Thailand. (WTO, 2019). Of the three countries, Indonesia accounted for 56.25 percent.

**Table 1. Ranking of the Top 10 World Palm Producers (in Ton Metrics)**

Number	country	Export
1	Indonesia	35,000.00
2	Malaysia	20,000.00
3	Thailand	2,300.00
4	Colombia	1,280.00
5	Nigeria	970.00
6	Ecuador	560.00
7	Honduras	545.00
8	Papua New Guinea	522.00
9	Ghana	520.00
10	Guatemala	515.00

Source: WTO, 2019.

In recent years, palm oil products are also increasingly in demand by people in European countries. This fact is proven by the increasing demand for palm oil by the EU. This data also shows that the number of palm oil consumers in the EU has increased quite rapidly. Although not as the world's largest consumer country, the consumption of palm oil by the EU has increased every

year. In 2018, EU oil palm consumption has increased from 8.3 percent in 2010 to 11.11 percent in 2018 (WTO, 2018) (Figure 1).

Figure 1. Main Consumer Countries of Palm Oil

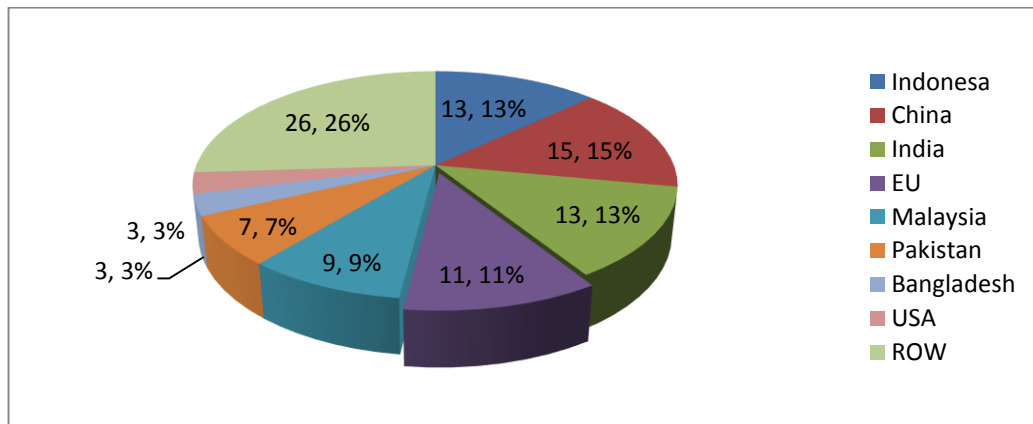

Source: WTO, 2018

This fact is quite surprising, considering that so far the EU is known as a society that prefers to produce other vegetable oils such as soybean oil and sunflower oil. Increased consumption of palm oil by the EU, causing demand for soybean oil and sunflower to decline. This condition triggers panic for the EU (Handley, 2017).

The anxiety over increasing exports of palm oil from ASEAN to the EU has actually been going on for a long time. Since two decades ago, efforts have emerged to prevent the entry of Indonesian palm products into the EU. Some excuses to prevent the entry of ASEAN palm oil include: the process of producing palm oil that causes deforestation, habitat degradation, violates human rights, inappropriate social standards and employs child labor.

Although the results of the vote must still have the support of the European Parliament plenary (early April), ultimately Europe will not stop palm oil imports because it is detrimental to Europe itself. The accusation is just an excuse to pass a new policy on palm oil imports into the European market. The combination of two new European policies for importing palm oil as discussed in the Committee, namely applying higher import duties on palm oil (which they refer to as embodied deforestation tax) that France had drafted. This policy is combined with the policy of having to certify the sustainability of European version of palm oil (European Sustainable Palm Oil, ESPO) which has been designed several years ago.

According to the EU, these reasons are the main principles that must be followed by palm oil producing countries, including Indonesia, Malaysia and Thailand. Nevertheless, this issue of sustainability and social justice also becomes an obstacle in the trade of palm oil from producing countries to consumer countries, such as the EU. Finally, in April 2017, the EU issued a resolution requiring the sole certification of the entry of ASEAN palm oil (Rodrik, 2018). The issuance of this resolution has threatened ASEAN palm oil exports including Indonesian palm oil.

Although the results of the vote must have the support of the European Parliament plenary (early April), ultimately Europe will not stop palm oil imports because it is detrimental to Europe itself. The accusation is just an excuse to pass a new policy on palm oil imports into the European market.

The combination of two new European policies for importing palm oil as discussed in the Committee, namely applying higher import duties on palm oil (which they refer to as embodied deforestation tax) that France had drafted. This policy is combined with the EU Palm Oil (ESPO) mandatory certification program for sustainability in the past few years.

Basically, the palm resolution issued by the EU Parliament does not only harm ASEAN countries. The EU countries themselves are also estimated to be negatively affected by the palm oil resolution. The EU has been very committed to reducing carbon emissions and as a source of biodiesel energy, while the source of biodiesel energy that has been used is derived from palm-derived products. With reduced supply of palm oil to these countries, the target to reduce emissions is disrupted and the use of biodiesel will be increasingly difficult because of the lack of supply of palm oil (Levitt et.al., 2019). This study aims to: (1) analyze the flow map of world palm oil trade; (2) analyzing the impact of palm resolution by the European Parliament on ASEAN performance of macroeconomic and trade; and (3) analyze the impact of oil palm resolution by the EU Parliament on the level of economic welfare of the EU itself.

## II. LITERATURE REVIEW

### 2.1. Trade Protection

Palm resolution by the EU parliament is one form of protection. With protection, it is expected that goods from outside cannot freely enter a region or country. Protection is a form of trade policy that is usually used to protect infant industry (Lee and Swegel, 2017).

The forms of protection are quite diverse namely tariffs, quotas, export subsidies, import restrictions. The import ban is also divided into 2 (two), namely a total ban or conditional ban. Palm resolution by the European Parliament is a conditional ban on imports, namely to enter the EU market, palm oil products from outside the region must pass a single certification from the EU (Khandewal et.al., 2016). Dengan syarat yang ketat, ekspor minyak sawit termasuk dari ASEAN ke UE akan turun. Harga minyaksawit akan naik dan dengan demikian permintaan minyak sawit akan turun. Selanjutnya apa yang akan terjadi?. Minyak nabati produksi Uni Eropa (minyak kedele dan minyak bunga matahari) akan meningkat permintaannya (Mary et.al., 2018, Lan et.al., 2017).

### 2.2. Equilibrium Theory

Theoretically, equilibrium in economic studies can be divided into two namely: First, the theory of partial equilibrium. This theory looks at the market partially. This theory is usually focused on one or several commodities and see price formation based on the relationship of supply and demand explicitly in the market (Haryadi, 2009).

Partial balance theory has several limitations. The effect of changing an independent variable such as price can only be observed in the quantity of demand and supply of the commodity itself, while the effect on changes in the demand and supply of other commodities cannot be seen simultaneously. In reality changes in the price of a product can have an impact on changes in demand and supply of other products (Haryadi, 2010).

The second theory of balance is the General Equilibrium Theory (CGE). The limitations of the partial balance theory above are one of the factors driving the emergence of CGE. This theory explains the market as a system. The CGE model is one model that is widely used by models in international journals (Haryadi, 2009).

The general equilibrium model or CGE is a multi-equation model (Hertel, 1997). With a detailed micro structure, these equations can be measured even if the number reaches thousands. This equation explains micro behavior in nonlinearity in general. This model considers that solving a balance is not a easy thing, but it is important to do.

Especially in developing countries, the results of economic policy analysis with a general equilibrium approach are often more appropriate than analyzes based on simultaneous equations. De Melo (1993) states that there is a problem in building and forecasting by using econometric models to analyze the impact of shocks in macroeconomics in a particular country. These problems include: the difficulty of getting long-term coherent data; often inconsistent data; and there are significant changes that occur in a policy regime. One of the balance models is the GTAP model.

The GTAP model is a general balance model that uses CGE as an analysis tool. The GTAP model is clearly explained by Hertel and Tsigas (1997) and Oktaviani (2008). The main difference between the national CGE model and the GTAP model lies in the area coverage. In the CGE model, interactions between different agents take place only in one country or region, whereas in the GTAP model interaction between agents takes place between regions. In addition, GTAP also includes global transportation and investment mobility. Thus, the GTAP model is able to explain the impact of policies between countries, while the national CGE model is limited to one region or country only.

### 2.3. Past Literature

Considering that the palm oil resolution was only launched two years ago, specific research has never been done. However, research on the imposition of trade barriers was conducted by Haryadi (2009). The research aims to see the impact of the implementation of domestic support and export subsidies by developed countries.

Haryadi (2010) examined the impact of the ASEAN free trade area (AFTA) on trade in the manufacturing industry in member countries. Haryadi (2010) shows that the implementation of AFTA has an impact on trade creation (increasing the volume of trade in the internal region) and trade diversion (diversion of trade from external to internal trade).

Haryadi (2012) examined the impact of export subsidies on agricultural products by developed countries on the performance of the economy in the world. The results showed that based on simulations, the impact of removing export subsidies by the EU and the United States of America (USA) varies. This policy can improve their welfare. Haryadi (2015) explores the impact of tariff elimination on the trade performance of each member country, especially for Indonesia. Using the GTAP model, the results show that the implementation of AFTA free trade will encourage the creation of trade and diversion of trade between AFTA.

Previous studies that have led to the impact of oil palm resolution have not been available, but there are three studies that look at the competitiveness of palm oil exports. Elwiza (2017), Ermawati and Yeni (2013) and Ewaldo (2015) analyzed the dynamics of the competitiveness of Indonesian and Malaysian palm oil exports in the international market. His findings show that Indonesian palm oil is more competitive compared to Malaysia in Asia, but in Europe, Malaysian palm oil is more competitive compared to Indonesia.

The competitiveness of Indonesia and Malaysia for palm oil products can be said to be above the world average, because the RCA index is more than one. Nayantakaningtyas and heny (2012) analyzed the competitiveness of Indonesian Crude Palm Oil (CPO) products in the international market and analyzed the strategies for increasing the competitiveness of Indonesian CPO. Based on the results of the analysis using the Berlian Porter System and revealed comparative advantages, it was concluded that Indonesia's CPO competitiveness is quite strong, but a strategy is still needed to strengthen CPO-derived products. This finding is consistent with Kairunnisa (2017).

### III. Research Method

#### 3.1. Data Types and Sources

This research uses secondary data. The main data used is the Global Trade Alalysis Project (GTAP) database version 10, published September 2019 and can be obtained from Purdue University. GTAP version 10 is the latest GTAP program that contains data including: input-output table, value added of the production sector, value of primary inputs and intermediate inputs, bilateral trade, transportation, protection levels, taxes, and subsidies from regions and sectors that are more than Previous GTAP (140 regions and 57 sectors).

For the purposes of this research an aggregation of regions and sectors is carried out. The amount of regional aggregation is determined by considering the position of ASEAN member countries which are the main producers of world palm oil. With these considerations in mind, Indonesia, Malaysia and Thailand are independent, while other ASEAN countries are aggregated into other ASEAN groups. While countries outside the group are grouped by region proximity.

#### 3.2. Metod of Analysis

Data were analyzed both qualitatively and quantitatively. Descriptive analysis is intended to see the development and trade flow of each country / region. This analysis is needed to determine the contribution of the AEC member countries in the oil palm trade. region. Quantitative analysis is carried out to measure the impact of palm oil resolution planned to be launched soon by Un Europe.

#### 3.3 Tools of Analysis

To answer the purpose of this first research, a descriptive analysis was used by conducting an in-depth analysis regarding the world trade flow map based on data contained in the GTAP database 10. To answer the second research objective, namely analyzing macroeconomic performance as the impact of palm resolution, an impact analysis was carried out using RunGTAP.

To answer the third research objective, a simulation was conducted on the impact on changes in the welfare of the EU society. Welfare improvement in this study was approached using equivalent variation. By definition, equivalent variation is the amount of money that must be given to someone if a change does not occur so that the person's welfare remains the same as the welfare if the change occurs (Just et.al., 1982). With this approach, it will be known whether the oil palm resolution policy will be able to improve the welfare of the EU community.

Based on the results of the study and through a consideration as mentioned earlier, countries / regions are aggregated into 13 (dubelas) regions (Table 2). Of these, three ASEAN countries namely Indonesia, Malaysia, Thailand are aggregated separately. In addition, other countries which are also the largest exporters of palm oil in the world, namely Colombia and Nigeria, each stand alone. This decision was made to clearly see the impact on the five main oil exporting countries of the world.

Table 2. Countries based on the GTAP data base.10.

	<b>New</b>	<b>region</b>	<b>Comprising</b>
No	Code	Description	old regions
1	Idn		Indonesia.
2	Mys		Malaysia.
3	Tha		Thailand.
4	Col		Colombia.
5	Nga		Nigeria.
6	REA	East Asia	China; Hong Kong; Japan; Korea; Mongolia; Taiwan; Rest of East Asia.
7	SEA	Southeast Asia	Cambodia; Lao People's Democratic Republ; Philippines; Singapore; Viet Nam; Rest of Southeast Asia. ; Brunei Darassalam

8	SA	South Asia	Bangladesh; India; Nepal; Pakistan; Sri Lanka; Rest of South Asia.
9	CUMX	North America	Canada; United States of America; Mexico; Rest of North America.
10	LA	Latin America	Argentina; Bolivia; Chile; Paraguay; Peru; Uruguay; Venezuela; Rest of South America; Costa Rica; Guatemala; Nicaragua; Panama; El Salvador; Rest of Central America; Dominican Republic; Jamaica; Puerto Rico; Trinidad and Tobago; Caribbean.
11	EU_28	EU 25	Austria; Belgium; Cyprus; Czech Republic; Denmark; Estonia; Finland; France; Germany; Greece; Hungary; Ireland; Italy; Latvia; Lithuania; Luxembourg; Malta; Netherlands; Poland; Portugal; Slovakia; Slovenia; Spain; Sweden; United Kingdom; Bulgaria; Croatia; Romania.
12	MENA	Middle East and North Africa	Bahrain; Iran Islamic Republic of; Israel; Jordan; Kuwait; Oman; Qatar; Saudi Arabia; Turkey; United Arab Emirates; Rest of Western Asia; Egypt; Morocco; Tunisia; Rest of North Africa.
13	Row	Rest of World	Australia; New Zealand; Rest of Oceania; Brazil; Ecuador; Honduras; Switzerland; Norway; Rest of EFTA; Albania; Belarus; Russian Federation; Ukraine; Rest of Eastern Europe; Rest of Europe; Kazakhstan; Kyrgyzstan; Rest of Former Soviet Union; Armenia; Azerbaijan; Georgia; Benin; Burkina Faso; Cameroon; Cote d'Ivoire; Ghana; Guinea; Senegal; Togo; Rest of Western Africa; Central Africa; South Central Africa; Ethiopia; Kenya; Madagascar; Malawi; Mauritius; Mozambique; Rwanda; Tanzania; Uganda; Zambia; Zimbabwe; Rest of Eastern Africa; Botswana; Namibia; South Africa; Rest of South African Customs ; Rest of the World.

Source: GTP 10 Database (data processed)

Table 3, shows the results of sector aggregation based on GTAP baseline 10. The number of sectors is aggregated to 12 (twelve). Sector selection is carried out through two stages of selection. The first stage is to select a sector that is a strategic sector and is available in the GTAP database.

Table 3. Sector Aggregation based on GTAP 10

No.	New Code	Sector Description	Comprising old sectors
1	Mswt	Palm Oil	Oil seeds; Vegetable oils and fats.
2	FSwt	Food using Palm Oil	Processed rice; Food products nec.
3	Grains Crops	Grains and Crops	Paddy rice; Wheat; Cereal grains nec; Vegetables, fruit, nuts; Sugar cane, sugar beet; Plant-based fibers; Crops nec.
4	Meat Lstk	Livestock and Meat Products	Cattle,sheep,goats,horses; Animal products nec; Raw milk; Wool, silk-worm cocoons; Meat: cattle,sheep,goats,horse; Meat products nec.
5	Extraction	Mining and Extraction	Forestry; Fishing; Coal; Oil; Gas; Minerals nec.
6	ProcFood	Processed Food	Dairy products; Sugar; Beverages and tobacco products.
7	TextWap	Textiles and Clothing	Textiles; Wearing apparel.
8	LightMnf	Light Manufacturing	Leather products; Wood products; Paper products, publishing; Metal products; Motor vehicles and parts; Transport equipment nec; Manufactures nec.
9	HeavyMnfc	Heavy Manufacturing	Petroleum, coal products; Chemical,rubber,plastic prods; Mineral products nec; Ferrous metals; Metals nec; Electronic equipment; Machinery and equipment nec.
10	Util_Con	Utilities and Construction	Electricity; Gas manufacture, distribution; Water; Construction.
11	Trans Comm	Transport and Communication	Trade; Transport nec; Sea transport; Air transport; Communication.
12	OthServ	Other Services	Financial services nec; Insurance; Business services nec; Recreation and other services; PubAdmin/Defence/Health/Educat; Dwellings.

### 3.4. Data Processing Method

The GTAP model is processed using RunGTAP software. The stages of data processing can be explained through Figure 2. The process of sector and country / region aggregation is carried out using GTAPAgg. Data processing with RunGTAP will be carried out using closure adjustments and shock in accordance with the research objectives. This processed data will produce outputs (out) such as solutions, volume changes, and decomposition.

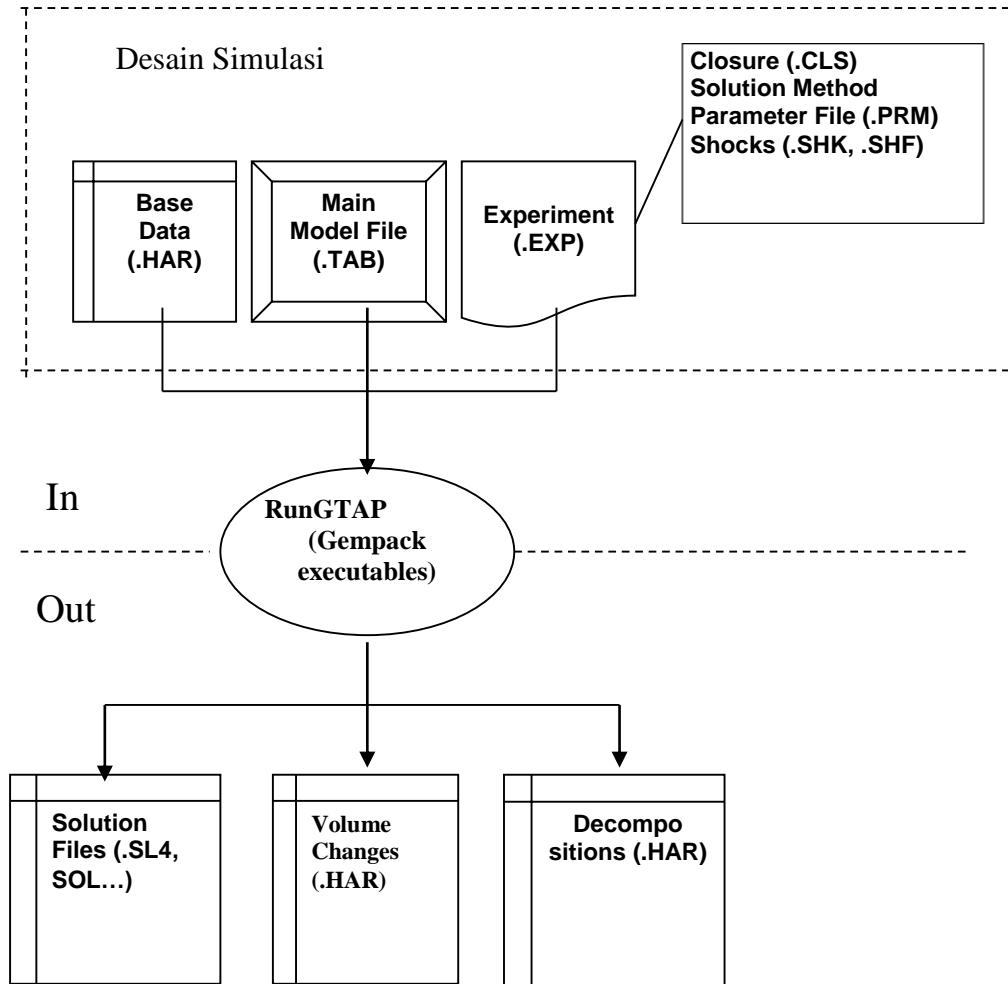

Figure 2. Utilization of the General Trade Analysis Project with the RunGTAP tool

### 3.5 Policy Simulation

As explained earlier, the palm oil resolution launched by the EU is thought to be merely an excuse to pass a new policy on palm oil imports into the European market. Based on this argument, a simulation is carried out by imposing import tariffs on palm oil entering Europe. This simulation assumes that the greater the tariff charged, the greater the damages. The scenario is that the EU imposes an import tariff of 10 percent. The import tariff is considered to include the cost of obtaining a single certificate.

## IV. RESULTS AND DISCUSSION

### 4.1. Map of the world oil palm trade flow

Table 14 summarizes export destination countries based on Main market share. The country is Indonesia's largest export destination to South Asia. Previously, the main purpose of Indonesia's palm oil exports was to EU Countries. But after the palm oil resolution adopted by the EU, Indonesia's market share shifted to the South Asian Countries. The policy issued by the EU made Indonesia switch its export destinations to other countries. It even placed the EU in the fifth rank of Indonesia's palm oil export destinations. Other export destinations for Indonesia are East Asian, Malaysian and African countries.

Table 4. Resume of World Palm Oil Trade Flow by Destination Country

No	Negara	Tujuan Ekspor				
		I	II	III	IV	V
1	Idn	SA	REA	Mys	MENA	EU
2	Mys	REA	SA	MENA	SEA	CUMX
3	Tha	Mys	EU	SEA	SA	REA
4	Col	LA	EU	CUMX	REA	
5	Nga	MENA	REA	EU	CUMX	

Keterangan:

Idn: Indonesia; Mys: Malaysia; Tha: Thailand; Col: Columbia; Nga: Nigeria; REA: Asia Timur; SEA: Asia Tenggara; SA: Asia Selatan; CUMN: Amerika Utara; LA: Amerika Latin; EU: Uni Eropa; MNA: Afrika Tengah, Utara, dan Timur; ROW: Negara-Negara Lainnya.

The second largest exporting country in the world is Malaysia with the largest market share is East Asia. Besides that Malaysia also exports palm oil produced to the South Asian Countries, Africa, Southeast Asia and North America. Other countries in Asia that export oil palm oil are Thailand, with the main export destination to Malaysia, besides Malaysia, Thailand also prioritizes its main exports to European countries despite the resolution policy that has been imposed by the EU, but this does not affect the main export destination of coconut oil. palm oil.

Countries outside of Asia that export palm oil, one of which is Columbia with the main export destination is Latin America, besides that Columbia also exports oil to countries, the EU, North America and East Asia. Besides Nigeria, Columbia also exports palm oil with the main export destinations to Africa, East Asia, the EU and North America.

Table. 5 explains the purpose of exporting food products to each country. Based on this table it can be seen that not a single ASEAN country makes the European Union as the main destination for export. Of the 5 (five) major exporting countries of the world, only Nigeria makes the EU the main destination for their export destinations. Indonesia and Thailand have even made the EU a leading destination for both countries' exports.

### 4.2. The Impact of the Implementation of the EU Palm Oil Resolution on the Macroeconomic Economic Performance of the Palm Oil Exporting Countries

It has been critically explained that the imposition of trade barriers in any form, including the resolution of palm oil issued by the EU, clearly has an impact on the economic performance of the countries exporting palm oil. However, the impact of palm oil resolution by the European Parliament actually does not only affect the macroeconomic performance of the exporting countries, but also has the potential to have an even broader impact and can even have an impact on the economies of the EU countries themselves. The greater the barriers to trade, the more theoretically it will affect the economies of the countries involved. This condition can further affect the national income of the countries concerned. In this context, changes in national income will further affect the economic growth of these countries. In this context, the elimination or reduction of trade barriers including oil palm resolution policies implemented by the European Parliament clearly impacts the economic performance of the exporting countries. Moreover, the resolution of the palm oil by the EU Parliament does not only have an impact on the macroeconomic performance of exporting countries, but can also have an impact on the performance of European countries and even the world. The greater the trade barriers will theoretically have a negative effect on exports of the palm oil producing countries themselves.



#### 4.2.1. The Impact of the Implementation of the EU Palm Oil Resolution on the Macroeconomic Performance of the Palm Oil Exporting Countries

In accordance with the research objective, which is to look at the impact, then some macroeconomic variables to be analyzed are nominal GDP, GDP deflator, real GDP, and TOT. These changes are analyzed in the form of a percentage change when the policy on implementing the palm oil resolution is realized. Table 6 presents the simulation results of the application of palm oil resolution to the macroeconomic performance of the EU oil palm trading partner countries. After doing the simulation, it can be seen that this policy has an impact on various macroeconomic variables both on nominal GDP, GDP deflator, real GDP, and Term of Trade (TOT) in each country. It's just because the focus is on ASEAN countries, especially the world's major palm oil exporting countries, the focus of the discussion is focused more on the three countries. Some countries benefit from this policy, while some are disadvantaged. The simulation results show that the countries that benefit are countries that import palm oil and its derivatives (except EU). Table 6. presents simulation results on the impact of oil palm resolution on the world economy. Based on the table, it can be seen that the palm oil resolution policy by the EU has different impacts for each country / region in the world. This table also shows that some countries benefit from this policy, while some countries suffer losses. The countries that benefit are countries that import palm products and their derivatives.

Table 6 also shows that the magnitude of direction and magnitude of impact also differ from country to country. Indonesia, along with Malaysia and Thailand, are countries that have been disadvantaged by this policy, even though the percentage change is not so significant. Based on Table 17, almost all palm exporting countries that are directly related to palm resolution experienced a decrease in nominal GDP, GDP deflator and TOT.

Table 6. Impact of the adoption of palm resolution by the EU on Nominal GDP, GDP Deflator, Real GDP and the Term of Trade of All Countries (% change)

Negara	GDP Nominal	GDP Deflator	GDP Riil	TOT
Indonesia	-0,02	-0,11	-0,03	-0,49
Malaysia	0,07	-0,08	-0,02	-0,33
Thailand	-0,23	-0,95	-0,63	-0,67
Columbia	0,72	0,75	-0,03	0,38
Nigeria	0,11	0,88	-0,27	0,61
East Asia	1,27	1,11	0,16	1,1
Other Southeast Asia	1,51	-1,96	-0,43	-0,05
South Asia	0,11	0,04	0,06	0,25
North America	0,14	0,03	0,02	0,02
Latin America	-0,36	-0,63	-0,12	-0,1
EU	-0,95	-2,56	1,76	-0,99
Midle, North, and East Africa,	0.10	0,15	0,10	0,09
South, East and North Africa	-0,11	-0,17	0,06	-0,02

However, Indonesia, Malaysia and Thailand have not been unduly disadvantaged by the EU's oil palm revolutionary policy. This relatively small impact is estimated because the EU is not the main destination country for exports to Indonesia and Malaysia. In the ASEAN context, the EU palm oil resolution turned out to have quite an impact on Thailand's macroeconomic performance, although the impact was still at a relatively small level (still below 1 percent). The relatively larger impact on Thailand's macroeconomic performance is reasonable, given that the EU is the second destination for exports of palm oil and palm products.

In detail it can be explained that the palm oil resolution only reduced Indonesia's nominal GDP of -0.02 percent. The negative impact also occurred on the GDP deflator growth of 0.11, real GDP of -0.03 percent and TOT of -0.49 percent. The second country that also experienced the worst effects of the palm oil resolution was Malaysia with a decrease in nominal GDP of -0.07 percent, GDP deflator -0.08 percent, real GDP of 0.02 percent, and TOT of -0.33 percent. Furthermore, negative effects were also experienced by Thailand by reducing nominal GDP, GDP deflator, real GDP and TOT respectively -0.23 percent, -0.95 percent, -0.63 and -0.67 percent. This figure is relatively bigger than the impact that occurred in Indonesia and Thailand, considering the EU is the second destination country for Thai exports.

Based on Table 6 it can also be seen that the oil palm resolution does not contribute positively to the EU's macroeconomic performance. The results of this simulation show that the oil palm resolution actually shows a counter productive impact on the EU's macroeconomic performance. Based on the simulation results, palm oil resolution has a negative impact on the EU Nominal GDP and Deflator GDP (although not as much as the negative impacts experienced by Indonesia, Malaysia and Thailand. Based on Table 5.1, the nominal GDP and GDP deflator of the EU are decreasing with the magnitude of each -0.95 percent and -0.65 percent Palm oil resolution only had a positive impact on the EU's total and GDP and even then with a relatively small impact of 1.76 percent and 0.99 percent respectively.



The negative impact of the palm oil resolution was not experienced by ASEAN3 countries (Indonesia, Malaysia, and Thailand), but also experienced by countries or regions that also produce palm oil in Latin America. Palm resolution has caused the region's nominal GDP to grow by -0.36, deflator's GDP to grow -0.63, and real GDP to grow -0.02 and TOT to grow -0.01. Similar to ASEAN countries, two other palm-producing countries, namely Columbia and Nigeria, were also disadvantaged. The resolution also experienced a change in macroeconomic performance that declined if the palm oil resolution was adopted at this time.

In contrast to the impacts experienced by Indonesia, Malaysia, Thailand, the EU, Columbia and Nigeria, the positive impact was actually picked by other countries / regions such as East Asia, Southeast Asia, North America, East and North Central Africa and other countries in the world. However, the positive impact of palm oil resolution is still in the relatively small category with a range of 0.11 percent to 1.5 percent. The results of this simulation show that the countries that benefit are countries that import palm oil products and their derivatives.

Meanwhile, countries that have not been producing palm oil or the country's position as net importers of palm products and their derivatives have no significant impact. For example, some regions such as East Asia have benefited from this resolution. This is reasonable considering the palm oil resolution will lead to trade creation in the form of an increase in the volume of trade between the three ASEAN countries (Indonesia, Malaysia, and Thailand) and the countries in East Asia which have become ASEAN trade partners. Besides that, trade diversion is also expected to occur in the form of trade diversion from the EU to other countries.

#### 4.2. Impact of the adoption of palm resolution by the EU on Sectoral Economic Performance

Sectoral economic variables that are the focus of attention in this study are the value of exports and imports. The simulation results of the impact of the adoption of palm resolution by the EU on these sectors are shown in Tables 7 and 8.

##### 4.2.1. Impact of the adoption of palm resolution by the EU on Export

The simulation results (Table 7) answer questions about the impact of the adoption of palm resolution by the EU on the export performance of countries / regions. Not all countries have experienced a decline in exports. Although there is a declining sector, but the figure is relatively small.

Table 7. Impact of the adoption of palm resolution by the EU on Exports (%)

qds	Idn	Mys	Tha	Col	Nga	REA	SEA	CUMN	LA	EU	ROW
Palm Oil	8,54	7,15	-10,69	-3,17	13,21	-9,28	16,53	1,83	-17,07	-71,35	-5,32
Food Palm Oil	1,72	-1,7	-65,8	12,03	194,93	-0,74	-16,25	-14,15	-1,79	-1,94	-5,15
Corn	8,74	0,36	-29,34	1,17	8,58	0,51	-0,36	5,77	2,01	-6,23	-0,97
GraCrop	2,79	-0,44	3,86	-0,53	-5,88	0,15	-3,85	-1,4	-1,8	-5,65	-1,73
MeaLstki	3,17	-29,62	-7,45	16,94	-3,33	4,38	-13,83	-1,22	-5,96	-24,8	-1,02
Extraction	13,04	-7,24	-20,06	-2,78	16,19	-5,41	19,49	6,1	-3,07	-36,39	-3,64
Procfood	-1,06	-0,95	10,35	0,24	0,01	3,59	-16,11	-2,05	-1,62	-33,65	0,34
Tectwapp	2,5	-1,11	-24,06	2,03	16,36	-1,38	0,93	0,45	1,96	-6,36	-1,53
Lightnfc	39,14	-4,89	-8,9	1,54	29,37	6,49	7,44	48,58	-0,46	-5,04	-1,65
HeavyMNFC	1,74	-13,01	1,05	-2,5	-95,34	-1,64	-14,49	-2,16	-1,87	-1,17	-5,09
Utilcins	-1,3	-0,72	0,78	-2,25	-4	1,31	-1,91	-0,19	-0,14	0,3	-0,29
PTranscomm	0,89	1,68	0,48	-0,16	5,83	0,23	0,51	1,73	0,01	0,01	-0,33
othserv	1,34	-0,22	-1,87	11,74	84,3	2,23	-1,74	3,16	-2,05	-5,83	-8,71

Source: Simulation results (processed)

Where:

Idn: Indonesia; Mys: Malaysia; Tha: Thailand; Col: Columbia; Nga:Nigeria; REA: Asia Timur; SEA: Asia Tenggara; CUMN: Amerika Utara; LA: Amerika Latin; EU: Uni Eropa; ROW: Rest of the world

Mswt: Palm Oil; Fswt : Food using Palm Oil ; GrainCorps; Extraction : Mining, fishing, Coal dll; Procfoods: dairy Product, sugaar, beverage and tobacco products; Textwapp:Textile and Clohing; LightMnfc : Costruction; Transcomm: transport and Communicaation;OtherService:

##### 4.2.2. Impact of the adoption of palm resolution by the EU on Imports

The simulation results (Table 8) answer the question about the impact of the adoption of palm resolution by the EU on the pseudo imports of each country / region. As shown in Table 20, not all countries experienced a decline in imports. The results of this simulation prove the trade theory which states that the imposition of trade barriers will have an impact on the decline in imports by countries in the world.

Table 8. Impact of the adoption of palm resolution by the EU on Import

Neg/Prod	Idn	Mys	Tha	Col	Nga	REA	SEA	CUMN	LA	EU	ROW
Mswt	8,54	7,15	-100,69	-3,17	13,21	-9,28	16,53	1,83	-17,07	-71,35	-5,32
Fswt	1,72	-1,7	-65,8	12,03	194,93	-0,74	-16,25	-14,15	-1,79	-1,94	-5,15
Jagung	8,74	0,36	-29,34	1,17	8,58	0,51	-0,36	5,77	2,01	-6,23	-0,97
GraCrop	2,79	-0,44	3,86	-0,53	-5,88	0,15	-3,85	-1,4	-1,8	-5,65	-1,73
MeaLstki	3,17	-29,62	-7,45	16,94	-3,33	4,38	-13,83	-1,22	-5,96	-24,8	-1,02
Extraction	13,04	-7,24	-20,06	-2,78	16,19	-5,41	19,49	6,1	-3,07	-36,39	-3,64
Procfood	-1,06	-0,95	10,35	0,24	0,01	3,59	-16,11	-2,05	-1,62	-33,65	0,34
Tectwapp	2,5	-1,11	-24,06	2,03	16,36	-1,38	0,93	0,45	1,96	-6,36	-1,53
Lightnfc	39,14	-4,89	-8,9	1,54	29,37	6,49	7,44	48,58	-0,46	-5,04	-1,65
HeavyMNFC	1,74	-13,01	1,05	-2,5	-95,34	-1,64	-14,49	-2,16	-1,87	-1,17	-5,09
Utilcins	-1,3	-0,72	0,78	-2,25	-4	1,31	-1,91	-0,19	-0,14	0,3	-0,29
PTranscomm	0,89	1,68	0,48	-0,16	5,83	0,23	0,51	1,73	0,01	0,01	-0,33
othserv	1,34	-0,22	-1,87	11,74	84,3	2,23	-1,74	3,16	-2,05	-5,83	-8,71

Source: Simulation results (processed)

Where:

Idn: Indonesia; Mys: Malaysia; Tha: Thailand; Col: Columbia; Nga: Nigeria; REA: Asia Timur; SEA: Asia Tenggara; SA: Asia Selatan; CUMN: Amerika Utara; LA: Amerika Latin; EU: Uni Eropa; MNA: Afrika Tengah, Utara, dan Timur; ROW: Negara-Negara Lainnya.

Mswt: PalmOil; Fswt : Food Using Palm Oil; GrainCorps; Extraction : Mining, fishing, Coal dll; Procfoods: dairy Product, sugar, beverage and tobacco products; Textwapp: Textile and Clothing; LightMnfc; Heavymnfc; Util-Cons: Utilitas and Construction; Transcomm: transport and Communication; OtherService:

Different cases occur in European countries / regions. As shown in Table 8 the imports of the oil-palm sector and its derivatives products. Almost all sectors experienced a decline in imports. Based on the above arguments, it can be interpreted that the increase in imports for certain cases is not entirely caused by a decrease in the competitiveness of domestic products. Increased imports can also be caused by diverse domestic demand and these needs can be imported from abroad.

#### 4.2.4. Dampak pemberlakuan resolusi sawit oleh Uni Eropa Terhadap Tingkat Kesejahteraan Masyarakat termasuk di UE

The simulation results (Table 9) answer the question about the impact of the adoption of palm resolution by the EU on the level of welfare of the community, both ASEAN countries and the EU itself. As shown in Table 9, this policy actually reduced the welfare of all countries, both countries / regions that are oil palm producers, as well as countries that implement palm resolution throughout the world. The decline in welfare in palm oil producing countries including in ASEAN (Indonesia, Malaysia and Thailand) was mainly due to a decline in exports to the EU. Meanwhile, the decline in the level of public welfare in the EU is expected to be due to a decrease in palm oil supply in the region due to high import taxes. Theoretically the decline in palm oil supply to the EU causes the price of palm oil to rise in the EU. The next impact is the inhibition of emissions reduction programs, increased use of biodiesel and others. Increased welfare of the people actually occurred in the East Asia, Southeast Asia (other than ASEAN3, Latin America, North America, South Asia and others, due to the diversion of trade by sawt producing countries from the EU market to these countries.

Table 9. Impact of the adoption of palm resolution by the EU on Welfare Levels (US \$ Million)

Country	Change in Welfare
Indonesia	-1352,88
Malaysia	-1442,22
Thailand	-2352,10
Columbia	-142,55
East Asia	853,93
The rest of Southeast ASIA	9,03
South Asia	1102,28
North America	108,23

Latin Amerika	36,40
European Unio	-3245,26
Middle, East, and North Africa	7423,94
ROW	2547,16

## V. CONCLUSIONS AND POLICY IMPLICATIONS

### 5.1. Conclusion

1. The EU is not yet a major export destination for ASEAN countries (Indonesia, Malaysia, and Thailand) although the market share of this region is quite large, only Thailand makes the EU the second export destination, Indonesia makes the EU as an export destination fifth, while and even Malaysia does not make the EU in the top 5 export destination countries.
2. The adoption of the palm oil resolution policy by the EU, although it has a negative impact on the macroeconomic performance of the world's palm exporting countries, but the impact is relatively small on the performance of the world economy, both macroeconomic performance and sectoral economic performance.
3. The policy on palm resolution does not only negatively affect the welfare level of palm oil exporting countries, especially Indonesia, Malaysia and Thailand, but also on the welfare of the EU itself.
4. Countries that benefit from palm oil resolutions are palm oil importing countries other than the EU as a result of the transfer of trade from the EU market to the markets of other importing countries, such as South Asia and Africa

### 6.2. Policy Implications

The Findings show that oil-producing countries have not yet made the EU their export destination. It is, however, as one of the export market shares, the palm oil exporting countries should negotiate with the EU so that the policies they take can be reconsidered, considering that palm oil products and their derivatives are also urgently needed by the EU, especially in reducing emissions and making palm oil an energy source to replace conventional fuels.

1. The results of the study indicate that oil palm resolution can have an impact on macroeconomic and sectoral economic performance. Therefore, to anticipate the worst possibility, the palm oil exporting countries, especially the countries of ASEAAAN (Indonesia, Malaysia, and Thailand) must diversify the market, by exploring the possibility of export opportunities to countries other than the EU, such as African region or to North America.
2. The results of the study show that the EU palm oil resolution policy actually harms the producing countries and the EU itself, including decreasing their welfare. Therefore, it is necessary to renegotiate between producing countries and the EU. Besides that, it is fitting for ASEAN countries to diversify their products so that they do not rely on oil palm as one of the mainstays in the agricultural sector. ASEAN countries should also increase the downstreaming of palm oil products, so that higher value added will be obtained. If this can be done, in addition to increasing income and creating employment opportunities for the community, it can also increase state revenue.

## REFERENCES

- Anonim. 2019. World Trade Organization (WTO). New York.
- Broocks, A and J Van Biesebroeck (2017), "The Impact of Export Promotion on Export Market Entry", *Journal of International Economics*, 107: 19-33.
- Ermawati T, Yeni Saptia. 2013. Indonesian Palm Oil Export Performance. LIPI Economic Research Center. Trade Litbang Scientific Bulletin, VOL.7 NO.2, December 2013
- Erwiza, 2017. Behind Palm Sustainability: Actors, Alliance in Political Economy of European Union Certification, Presented in the Academic Forum On Sustainability I. D2sdr (Lipi) in Jakarta, 31 January 2017
- Ewaldo, Ega.2015. Analysis of palm oil exports in Indonesia. E-Journal of Trade, Industry and Monetary Vol. 3. No.1, January-April 2015.
- Fajgelbaum, Pablo, Pinelopi K. Goldberg, Patrick Kennedy and Amit Khandelwal. 2018. The Return to Protectionism: Causes and Consequences of the 2018 Trade War. Yale University, mimeograph.
- Handley, Kyle and Nuno Limão 2017 Policy Uncertainty, Trade and Welfare: Theory and Evidence for China and the U.S.,” *American Economic Review*, 107(9): 2731-2783.
- Haryadi, 2009. The implementation of special tariff for agricultural products and its impact on small medium enterprises of Indonesian agricultural products. Paper presented in Sidang pleno IV dan seminar nasional, Bandung, 20-22 juli

- Haryadi, 2010. Impacts Of Asean Free Trade Area (AFTA) on It's Intra Manufacture Trade. Presented on 35<sup>th</sup> the Federation of ASEAN Economist Association (FAEA) Annual Conference in Bali, Indonesia 1-3 December 2010.
- Haryadi, 2012, Impact of Agricultural Export Subsidies Elimination by Developed Countries on The Performance of Asean Macroeconomies And Indonesian Trade Balance, \*Paper presented in the 3<sup>rd</sup> International Regional Science Association (IRSA), International Institute Seminar held in Padang, West Sumatra, Indonesia, on July 19-21, 2011.
- Haryadi, 2015. The Impact of The AFTA Free Trade Agreement In Manufactured Trade of The Member Countries. *South East Asia Journal of Contemporary Business, Economics and Law*, Vol. 6, Issue 3 (Apr.) ISSN 2289-156
- Hertel, T.W and M.E. Tsigas. 1997. Structure of GTAP. In *Global Trade Analysis Modeling and Applications* Cambridge University Press, Cambridge.
- Hertel, T.W, 1997, *Global Trade Analysis: Modeling and Applications*, Cambridge University Press, Cambridge.
- Hidayat S, Marimin, Ani Suryani, Sukardi, Mohamad Yani. 2012. Risk Identification Model and Value Added Strategy for Palm Oil Supply Chain. *Journal of Industrial Engineering*, Vol. 14, No. 2, December 2012, 89-96 ISSN 1411-2485 print / ISSN 2087-7439 online
- Just, R.E., D.L. Hueth and A. Smith. 1982. *Applied Welfare Economics and Public Policy*. Prentice Hall, London
- Khairunisa GR, and Tanti Novianti. 2017. Competitiveness of Palm Oil and the Impact of the European Union Renewable Energy Directive on Indonesian Exports in the European Union Market. *Indonesian Agribusiness Journal* (Vol 5 No 2, December 2017)
- Khandelwal, Amit Kumar, Jan De Loecker, Pinelopi Goldberg, and Nina Pavcnik. 2016. "Prices, Markups and Trade Reform," *Econometrica*, 84(2), 445-510
- Mary Amiti, Stephen J Redding, David Weinstein, 2019. The Impact Of The 2018 Trade War On U.S. Prices And Welfare, Working Paper 25672 [Http://Www.Nber.Org/Papers/W25672](http://www.nber.org/papers/W25672). National bureau of economic research. 1050 Massachusetts Avenue. Cambridge
- Lan J, Munro A, Liu Z . 2017. Environmental regulatory stringency and the market for abatement goods and services in China. *Resour Energy Econ* 50:105–123
- Lee JW, Swagel P. 2017. Trade barriers and trade flows across countries and industries. *Rev Econ Stat* 79(3):372–382
- Levitt CJ, Saaby M, Sørensen A. 2019. The impact of China's trade liberalisation on the greenhouse gas emissions of WTO countries. *China Econ Rev* 54:113–134
- Nayantakaningtyas JS dan heny k. Daryanto. 2012. *Departemen Agribisnis, Fakultas Ekonomi dan Manajemen, Institut Pertanian Bogor*. *Jurnal Manajemen & Agribisnis*, Vol. 9 No. 3, November 2012
- Oktaviani, R. 2000. The Impact of Trade Liberalization on Indonesian Economy and Its Agricultural Sector. PhD Thesis. Department of Agricultural Economics, University of Sydney, Sydney.
- Rodrik, Dani. 2018. What Do Trade Agreements Really Do?. *Journal of Economic Perspectives—Volume 32, Number 2—Spring 2018—Pages 73–90*.

Haryadi  
Professor in International Economics,  
Department of Economics,  
Faculty of Economics and Business  
University of Jambi, Indonesia.  
E-mail:haryadi\_kamal@yahoo.com

Siti Hodijah  
Lecturer,  
Department of Economics,  
Faculty of Economics and Business  
University of Jambi, Indonesia